



VAC-AIR INDUSTRIES



User Guide

Model VAV-2 Stick Hole Cutter



| Table of Contents | Page |
|---------------------------|-------------|
| Introduction | 2 |
| Specifications | 2 |
| Safety Warnings | 2 |
| Installation | 3 |
| Operation | 4 |
| Maintenance | 5 |
| Motor Assembly | 7 |
| Assembly Drawing | 8 |
| Parts List | 9 |
| Declaration Of Conformity | 10 |

Patent No. 4,884,341

5254 N. 124th Street
Milwaukee, WI 53225
(414)353-5270 | vacairind.com

Introduction

Important!

Please read these operating and safety instructions carefully before using this equipment.

Your safety is our priority. If you are uncertain about how to operate this equipment, do not proceed without assistance. For technical support or questions, please contact Vac-Air Industries.

Contact information, including our phone number, can be found on the Vac-Air Industries website.



www.vacairinc.com

Congratulations on Your Purchase!

Thank you for choosing Vac-Air Industries. With proper installation, use, and maintenance, your new tool is designed to deliver years of reliable, trouble-free, and industry-leading performance.

Important Installation Information:

- If your purchase included a filter/regulator/lubricator and tool balancer, please refer to the relevant installation instructions provided in this manual.
- If you purchased the tool only, you may skip the installation instructions for the regulator, lubricator, and tool balancer. Please proceed directly to the Tool Installation section.

Description

The VAV-2 Stick Hole Cutter is designed for manual vent cutting. The cutter utilizes compressed air and trims the skin patch and jowl meat, as it drills the hole and improves blood flow. The ergonomic trigger system makes this rotary tool easy to use. With its non-clogging design and no need for an overhead valve system, it cuts costs and boosts efficiency.

Advantages

- Improves Yield
- Improves Blood Flow
- Continuous Cleaning
- One Trigger Operation

Specifications

- Maximum Operating Air Pressure: 100 Psi
- Blade Length
- Blade size: 2" x 3-5/8"
- Length: 12", Width: 3", Height: 7"
- Weight: 5lbs, Machine Complete: 10lbs

Safety Warnings

Keep hands away from blade.

Wear Proper Personal Protective Equipment (PPE)

- PPE must conform to PPE Regulation (EU) 2016/425
- Always wear safety glasses or goggles to protect against flying debris.
- To prevent hearing loss caused by prolonged exposure to noise generated by pneumatic hand tools, an exhaust muffler must be used at all times.
- Wear hearing protection in noisy environments.
- Use mesh gloves and non-slip footwear as needed.

Air Supply Safety

- Use clean, dry, regulated compressed air only. Do not use bottled gas or oxygen.
- Never exceed the maximum air pressure rating of the tool.
- Use appropriate air hoses and fittings rated for the pressure and application.

Inspect Before Use

- Inspect the tool, air hose, and fittings for damage or wear before each use.
- Do not use a damaged or malfunctioning tool—report and replace it immediately.

Secure the Work Area

- Ensure the work area is **clean, dry, and well-lit**.



- Keep bystanders, especially children, away from the work area.

Tool Handling

- Always shut off the air source and release any remaining air pressure in the lines before detaching or servicing the tool.
- Never point the tool at yourself or others.
- Maintain a firm grip and proper stance while operating the tool.



Vac-Air Industries Hand Tools are **not intended for use by:**

- Individuals **under 18 years of age**
- **Untrained personnel**
- Persons **under the influence of drugs, alcohol, or medication** that may impair judgment or coordination

Improper use may result in injury or equipment damage.

Vac-Air Industries is not responsible for the safety of any Vac-Air Industries tool used for purposes other than those specified as intended.

For user safety, it is **strongly recommended** to keep a **fully stocked first aid kit** readily accessible to treat minor injuries.

Important: Never remove or disable any **guards or protective devices** installed on Vac-Air Industries hand tools. These safety features are essential for preventing serious injury and must remain in place during all operations.

Note: Tampering with or removing the safety guard invalidates conformity with European Regulation 2023/1230. Vac-Air Industries accepts no responsibility for any consequences resulting from such actions.

Staging, access steps, handrails, and kick plates that assist the user must be designed and constructed in accordance with EN ISO 14122-2:2016 – Safety of Machinery

Risk Assessment

Hazard: Use of a hand tool to cut materials other than poultry and other meat.

Risk: Tool damage and possible operator injury due to tool failure or overload.

Hazard: Exposure to hazards if the safety guard is tampered with or removed.

Risk: Risk of severe cuts, amputations, or other injuries from contact with moving or sharp parts.

Hazard: Exposure to ejected parts such as broken metal fragments when the cylinder or motor housing cannot withstand high internal pressure due to an improperly set pressure relief valve.

Risk: Injury from flying debris; damage to 'O' rings or housing leading to tool failure.

Hazard: Exposure to hazards from a hand tool that has been modified to change its intended purpose.

Risk: Unpredictable tool behavior, mechanical failure, or serious injury.

Hazard: Operation of the tool by untrained persons, persons under the influence of drugs, or underage operators.

Risk: Increased likelihood of accidents due to lack of training, impaired judgment, or physical inability to operate safely.

Installation

Tool Balancer Installation

Installation (Fig.1)

Hang the balancer using the main hook.

Keep the balancer spaced properly to avoid collision with other balancers or structures.

Install the tool onto the balancer using the spring clip at the end of the cable.

The support cable must be installed on secondary hanger.

The **cable** used for suspension must **not come into contact with any fixed surfaces** to avoid wear and potential failure.

Tension Adjustment (Fig. 2)

To increase the tension, pull up on the knob below the handle and turn clockwise.

To decrease the tension, pull up on the knob below the handle and turn counter clockwise.

Caution (Fig. 3)

Do not pull cable at an angle as this can cause damage to the balancer.

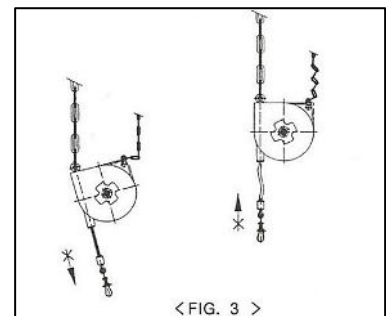
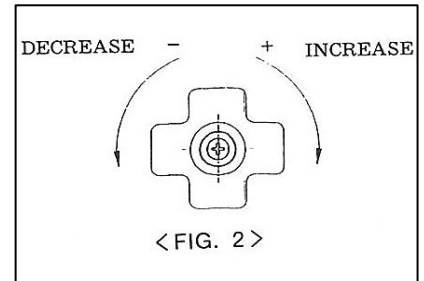
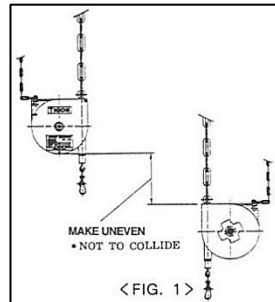

Filter/Regulator/Lubricator Installation

Always turn off power of the air compressor and fully exhaust air pressure before installing or servicing the filter/regulator/lubricator (FRL) assembly. (Fig. 4)

Ensure that the air is completely exhausted prior to performing any actions.

Connect piping to the designated ports using pipe thread sealant on male threads only.

Do not allow sealant to enter the interior of the FRL assembly, as this may cause malfunction or contamination.

Install the assembly with airflow aligned to the directional arrow marked on the body.

Position and install the assembly as close as possible to the point of tool use to ensure optimal performance.

Fill the lubricator with oil. (see Lubrication section)

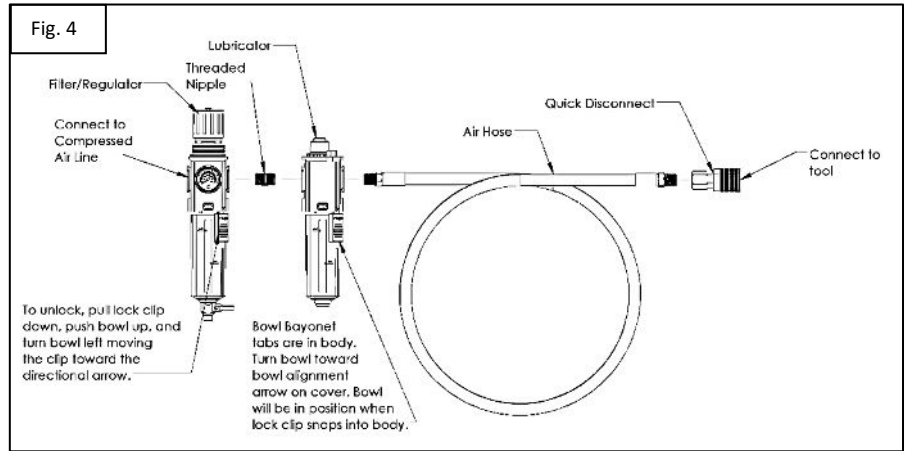

Accessories: Filter/Regulator/Lubricator Mounting Bracket

Important: Installers of compressed air, water, and vacuum sources must provide isolation valves that can be shut off and locked in the **OFF** position to ensure safe maintenance and servicing.



Tool Installation

Attach the clip on the end of the balancer to the eye-bolt attached to the top of the tool.

This will allow the tool to suspend from overhead. (Fig. 5)

Lower the tool to working level using the adjustment on the tool balancer.

Attach the air hose to the tool using the quick disconnect at the end of the hose. (Fig. 5)

Suspend the air hose from overhead to reduce tension on hose.

Adjust the air pressure on the air pressure regulator to proper working air pressure. (80psi-100psi recommended)

It is unsafe to set the pressure relief valve above the clearly specified safe operating pressure. Doing so may result in equipment failure or personal injury.

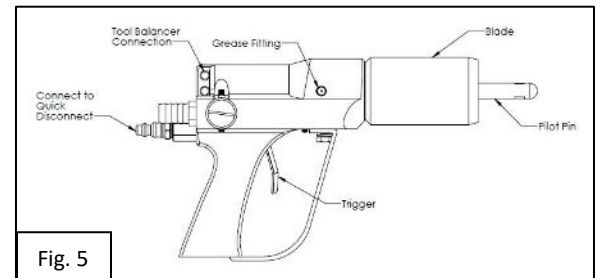

Operation

Clean, dry compressed air and proper lubrication are essential to ensure optimal tool performance and to extend the life of all components.

Contaminated air and inadequate lubrication can lead to premature wear, reduced efficiency, and costly downtime. Maintaining these conditions is critical for the reliable and long-term operation of your equipment.

This tool is designed solely for poultry processing and evisceration. It must not be used on metal, plastic, or other non-organic materials, as this can reduce performance and lead to contamination.

Check Air Connections

- Ensure the air hose is securely connected to the tool's air inlet.
- Inspect the hose for any signs of damage, wear, or leaks.
- Confirm that the air supply is turned on and operating at the correct pressure as specified for the tool.



Engage and Use the Tool

- **To operate the blades:** Press the trigger to engage the blade.
- **To open the blade:** Release (depress) the trigger.
- The tool will only re-engage the blade when the trigger is pressed again.

Important: Do not operate the tool if any air connections are insecure or if there are any loose components.

Always perform the above checks before each use.

Lubrication

Required Lubrication: *Food Machinery Oil ISO 46 / Food Grade Hydraulic White Mineral Oil A/W*

Food Industry Grease, Food-Grade

Check oil in the lubricator before operation of the tool by using the sight glass. If low, unscrew the fill cap and fill to max oil fill line. Proper lubrication will ensure long lasting and proper functionality of the tool. The oil will help lubricate moving parts and lengthen the life of the internal seals.

- **Required lubrication for machine:** 1 drop (.05mL) of oil into tool per 10 cycles.
- **Use the grease gun to grease the bearing through grease fitting (#94) on the body (#1).** (shown in VAV-2 Machine Assembly)

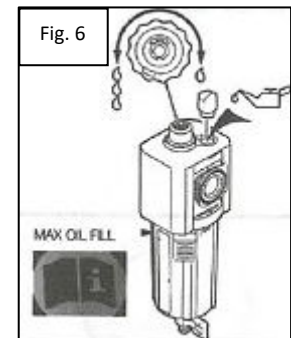

Accessories: Grease Gun

Maintenance

Vac-Air Industries allows users to perform all routine preventative maintenance, including cleaning, lubrication, and basic inspections. However, if major maintenance or repairs are needed, such as internal component replacement or motor issues, the tool should be sent to Vac-Air Industries for servicing.

Note: In order to maintain conformity to European [Regulation 2023-1230](#), only Vac-Air replacement parts must be used.

It is advised to keep a spare tool available for use while another tool is undergoing maintenance. Maintenance should be performed in a designated clean and controlled area to ensure proper handling and minimize contamination.

CAUTION:

Always shut off the air supply and release all remaining air pressure from the lines before detaching or servicing the tool. Failure to follow this procedure can result in serious injury due to unexpected tool activation or discharge.

Before handling or inspecting the tool:

- Keep hands away from the blade.
- Press the trigger lever to confirm that no air pressure remains in the system.



| Preventative Maintenance | Occurrence |
|-------------------------------|-------------------------------------|
| Inspect components for wear | Daily |
| Check Oil Level in Lubricator | Daily |
| Grease between the blades | 800 cycles |
| Inspect Blade | Daily |
| Sharpen Blade | 800 cycles or if blades become dull |
| Clean the tool | Daily |

Store tool in a clean, dry place when not in use.

Blade Removal-

Caution: Keep hands and arms away from the blade while performing this procedure to avoid risk of **serious injury**.

Disconnect the tool from the air supply to ensure safety before beginning any maintenance.

Secure the tool in a vise, ensuring it is stable and will not shift or move during disassembly.

Hold the blade firmly to ensure it does not spin during the process.

Locate the flat section on the pilot pin.

Use a wrench on the flat to turn and loosen the pilot pin.

Once loosened, unscrew the pilot pin by hand and set it aside.

Carefully lift the blade away from the tool.



Vacuum Adjustment-

If the vacuum level is too low, the orifice in the vacuum valve passage can be enlarged to increase vacuum flow. Follow the steps below to adjust: (Fig. 6)

Loosen the #75B set screw nut.

Loosen set screw #75A.

Remove the cap and spring.

Slide the piston to enlarge the orifice and increase airflow.

Once the piston is in the desired position, tighten set screw #75A and the #75B nut to lock the piston in place.

Important Notes

- Higher vacuum = greater suction, improving vent engagement with the blade.
- Adjust the orifice size as needed to maintain a vacuum range of 14–18 inches.

Always ensure all components are securely reassembled after making adjustments

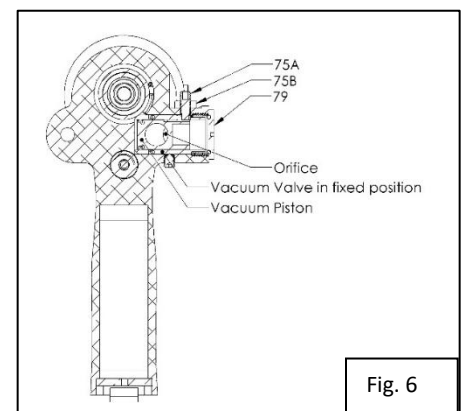

Fig. 6

Cleaning Instructions-

CAUTION: Always shut off the air, water and vacuum supply and release all remaining pressure from the lines before detaching, servicing, or cleaning the tool.

Failure to do so may result in serious injury due to unexpected tool activation or discharge.

Important: To maintain hygiene and prevent contamination, thoroughly clean all tool surfaces—including corners, joints, and hard-to-reach areas—where residue or debris can accumulate and lead to build-up.

For best results:

- Use warm water and a mild detergent (such as dish soap) to clean all applicable parts.
- Rinse thoroughly with hot water to remove all cleaning agents and residue.
- Ensure all areas are completely dried before reassembly or storage.



Important:

Do not use alkaline, iodine-based, or acidic cleaners, as these substances may cause corrosion or damage to tool components. Following these cleaning practices helps preserve tool performance and supports a hygienic working environment

For proper sharpening and/or maintenance, send the blades or the tool to Vac-Air Industries.

Vac-Air Industries
5254 N. 124th Street
Milwaukee, WI 53225
(414)353-5270 | vacairind.com

Vac-Air Industries

DRAWN BY: DJZ DATE: 8/14/2025

SIZE: DWG. NO. VAV-2 Stick Hole Cutter Assembly

SCALE: 1:3.5 WEIGHT: 9.5lbs SHEET 1 OF 1

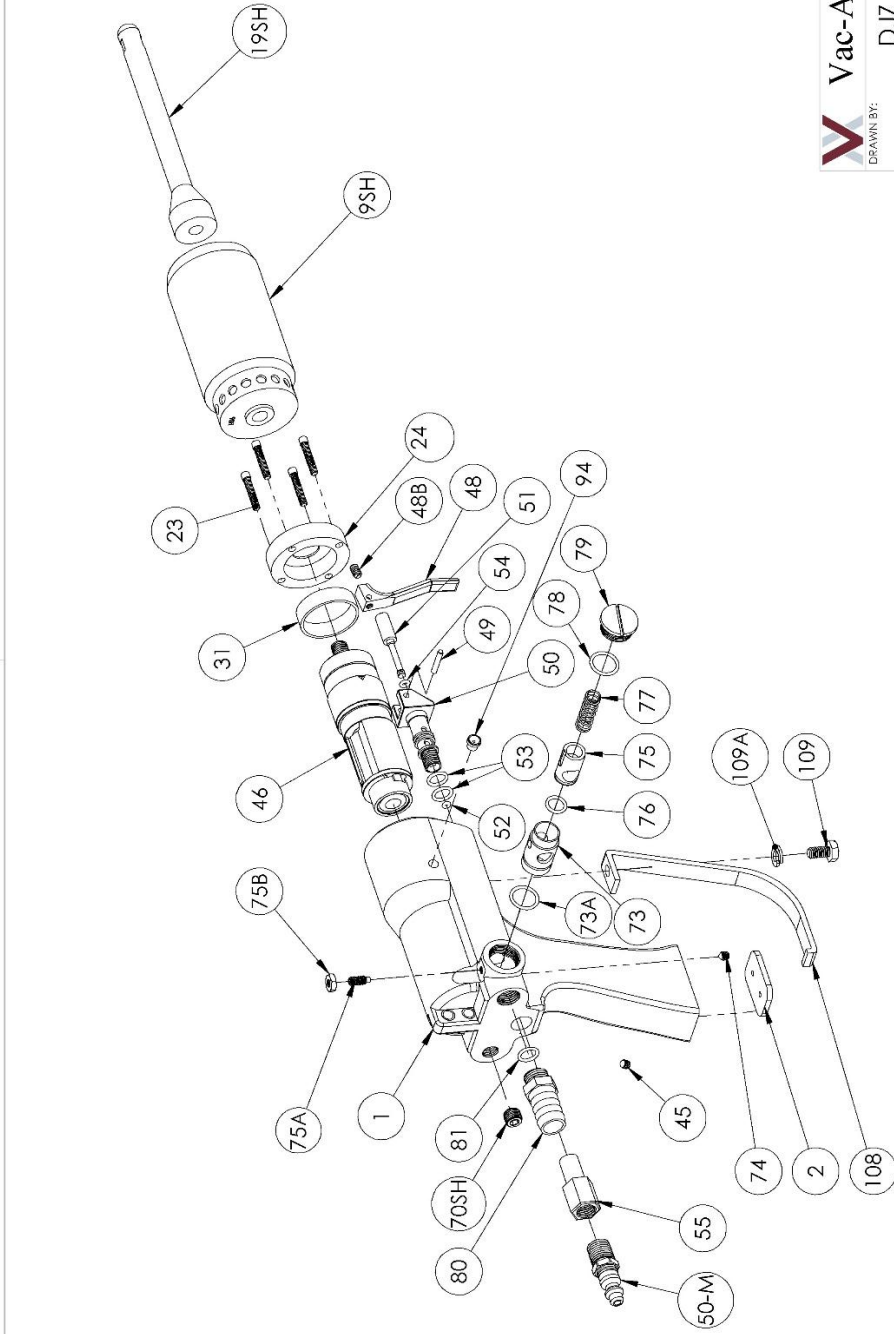

1

2

B

A

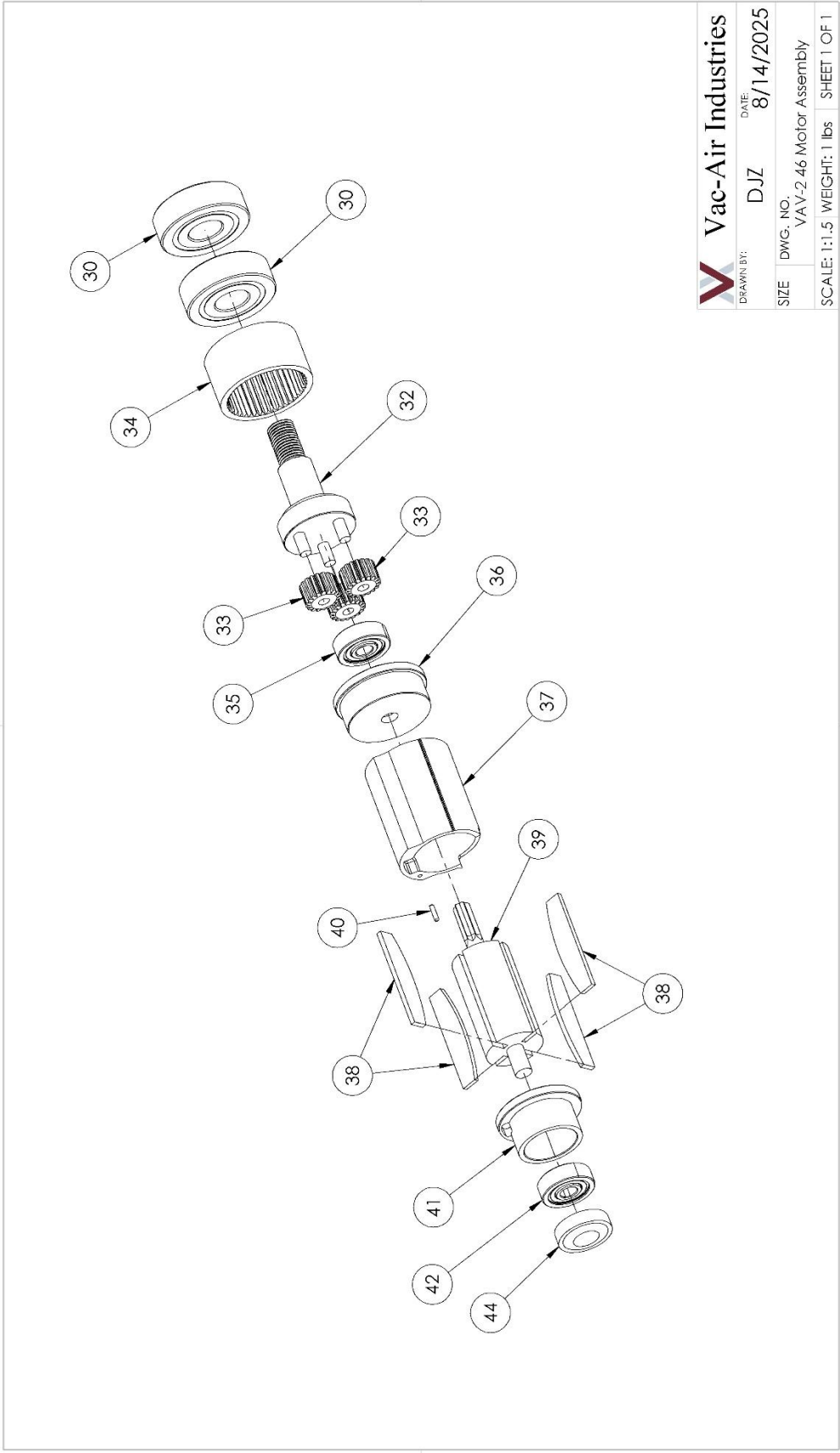

| | |
|--|----------------------------|
| Vac-Air Industries | |
| DRAWN BY: DJZ | DATE: 8/14/2025 |
| SIZE: DWG. NO. VAV-2.46 Motor Assembly | |
| SCALE: 1:1.5 | WEIGHT: 1 lbs SHEET 1 OF 1 |

1

2

B

A

| VAV-2 Stick Hole Cutter | Part # | VAV-2 Stick Hole Cutter Parts List | QTY |
|-------------------------|---|--|-----------------|
| | 1 | Body | 1 |
| | 2 | Air Screen | 1 |
| | 9SH | Blade (Select the correct blade) | 1 |
| | 19SH | Pilot pin (Select the correct pin, use the table below) | 1 |
| | 23 | Screw (4 required) | 4 |
| | 24 | Spacer | 1 |
| | 31 | Bearing retainer | 1 |
| Motor | 30 | Spindle Ball Bearing (2 Required) | 2 |
| | 32 | Idler gear plate | 1 |
| | 33 | Idler gear (3) | 3 |
| | 34 | Ring gear | 1 |
| | 35 | Front End Plate Bearing | 1 |
| | 36 | Front end plate | 1 |
| | 37 | Cylinder | 1 |
| | 38 | Rotor blade-4 Required (price per blade) | 4 |
| | 39 | Rotor | 1 |
| | 40 | Pin | 1 |
| | 41 | Rear End Plate | 1 |
| | 42 | Rear End Plate Bearing | 1 |
| | 44 | Bearing cap | 1 |
| | | 45 | Motor set screw |
| | 46 | Motor assembly | |
| Trigger Assembly | 48 | Trigger (VA-10 Short Trigger) | 1 |
| | 48B | Trigger Set Screw | 1 |
| | 49 | Trigger pin | 1 |
| | 50 | Brass air body | 1 |
| | 51 | Air valve | 1 |
| | 52 | Air intake o-ring | 1 |
| | 53 | Static o-ring (2 required) | 2 |
| | 54 | Air exhaust o-ring | 1 |
| | 55 | Valve air coupling | 1 |
| | 70SH | Water Plug | 1 |
| 73 | Vacuum sleeve | 1 | |
| 73A | Vacuum sleeve o-ring | 1 | |
| 74 | Vacuum sleeve set screw | 1 | |
| 75 | Vacuum valve piston | 1 | |
| 75A | Vacuum piston set screw | 1 | |
| 75B | Vacuum Piston Set Screw Hex Nut | 1 | |
| 76 | Vacuum valve o-ring | 1 | |
| 77 | Vacuum valve spring | 1 | |
| 78 | Vacuum cap seal o-ring | 1 | |
| 79 | Vacuum cap | 1 | |
| 80 | Vacuum Fitting | 1 | |
| 81 | Vacuum Fitting O-Ring | 1 | |
| 50M | Coupler Plug | 1 | |
| VA-52 | Air Quick Disconnect | | |
| 91 | 1/4" Filter/Regulator, filter, lubricator, assembly | | |
| 93 | Reel tool balancer 5 lb. S.S. | | |
| 94 | Grease fitting | 1 | |
| 108 | Trigger guard | 1 | |
| 109 | Trigger guard screw | 1 | |
| 109A | Trigger Guard Locking Washer | 1 | |
| | | | |
| | | | |
| | | | |

EC Declaration of Conformity



VAC-AIR INDUSTRIES

Manufacturers Name: VAC AIR INDUSTRIES
Manufacturers Address: 5254 N. 124th Street
Milwaukee,
WI 53225.

Declare that the machinery described below complies with all applicable health and safety requirements of Annex III Chapter 1 of Machinery Regulation 2123/1230 and applicable parts of Annex III Chapter 2 Subsection 2.2. Confidential Technical Documentation has been compiled in accordance with Annex IV Part B of Machinery Regulation 2123/1230 and is available to European National Authorities on written request only. If a request is received, documentation will be provided on a CD or sent by email.

Description: Pneumatic Roary Hand Tools.
Model Numbers: VA OGC Oil Gland Cutter and VAV-2 Vent Cutter

Serial Number/s: (As applicable)

The following standards have either been referred to in part or complied with in full, as applicable.

| | | |
|-----------------------|-------------------------------------|--|
| EN ISO 12100: 2010 | Machinery Safety | - Safety of machinery - General principles for design - Risk assessment and risk reduction. |
| EN ISO 13857:2008 | Safety of machinery | - Safety distances to prevent hazard zones being reached by upper and lower limbs. |
| EN 614-2:2000+A1:2008 | Safety of machinery | - Ergonomic design principles - Part 2: Interactions between the design of machinery and work tasks. |
| EN ISO 14120:2015 | Safety of machinery | - General requirements for the design and construction of fixed and movable guards. |
| EN ISO 14120:2015 | Safety of machinery | - General requirements for the design and construction of fixed and movable guards. |
| EN ISO 4414:2010 | Pneumatic fluid Power | - General rules and safety requirements for systems and their components. |
| EN ISO 11148-2 | Hand-held non-electric Power Tools. | - Safety requirements - Part 2 Cutting-off and crimping power tools. |
| EN ISO 15744:2008 | Hand-held non-electric Power Tools | - Noise measurement code - Engineering method. (ISO 11553-3:2013 accuracy grade 2) |

Full Name of Natural or Legal Person

Name: David H. Zanon Jr..... (Typed)
Position: Owner (Typed)

Place of Signing

Vac-Air Industries
5254 N. 124th Street
Milwaukee WI, 53225

Signature: *David H. Zanon Jr.* **Date** 5/27/2025

Full Name of Authorised European Representative **Place of Signing**

EU AR: QNET B.V.
Name Drs. Ton Denissen, CEO
Date May 27, 2025
Place of Signing Haaren
Ton Denissen